

WOODWORKS: INTERMEDIATE PROJECT 2011-2012 STORAGE BINS

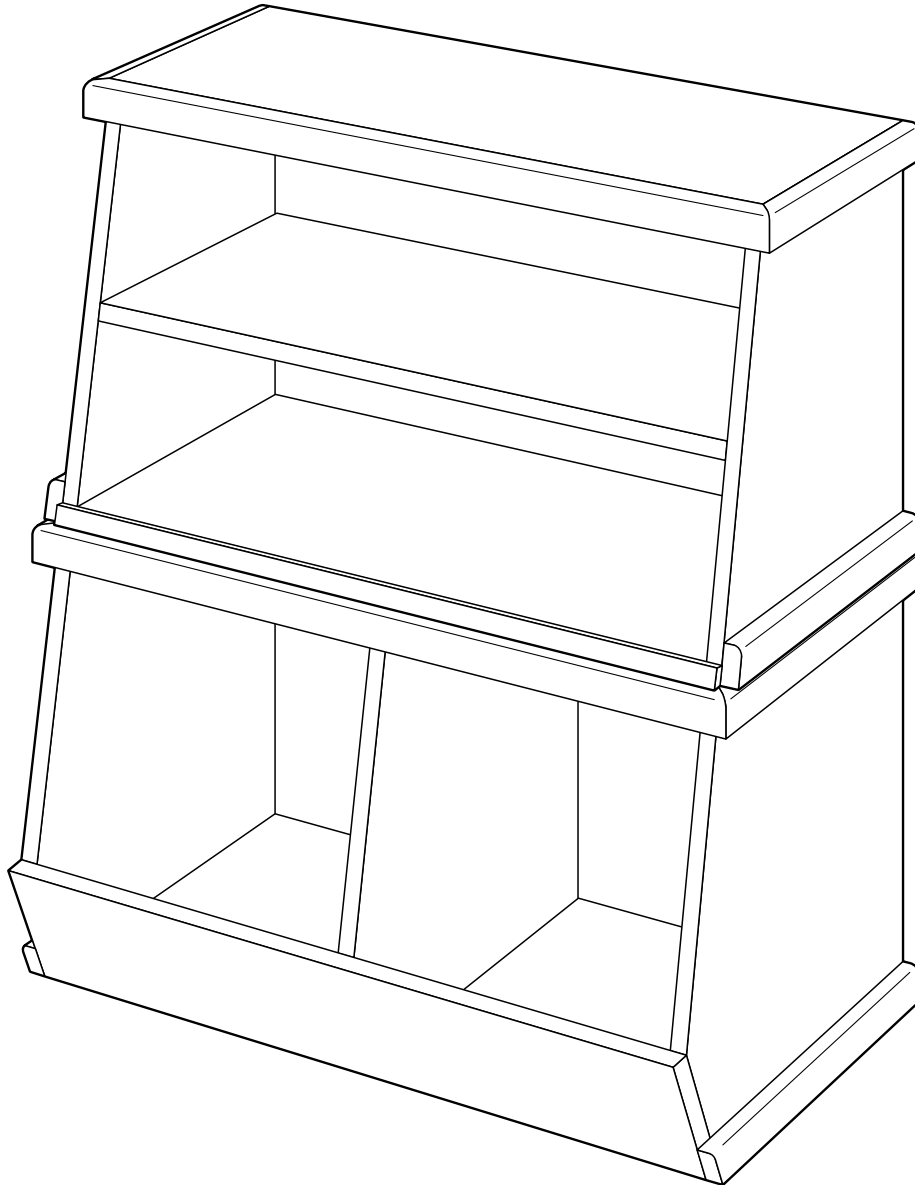

So maybe your room's a little messy; maybe it's a minor disaster, or somewhere in between. Here is a great way to store some of your wayward stuff. These storage bins will not only help organize your room, but they'll also stand out as great-looking pieces of furniture. Stack them one atop the other or use them separately, and you'll be on your way to conquering clutter. This is also a great woodworking project. Intermediate woodworkers will get a lot of practice finding, figuring and cutting angles; making joints with biscuits; and joining boards to create wide panels. And after you build it, you will learn more about applying and using finishes to protect the wood and keep it looking beautiful.

TOOLS REQUIRED

Hand Tools

- Bevel square
- Sanding block
- Pipe or bar clamps, C-clamp
- Adjustable square

Power Tools

- Belt sander
- Table saw
- Biscuit joiner
- Miter saw
- Router with 1/4" round-over bit
- Orbital or finish sander

Miscellaneous

- Tape measure
- Pencil
- Exterior wood glue
- Double-faced tape
- Safety glasses
- 120-grit sandpaper
- Clean, lint-free cloths
- Respirator
- Gloves for finishing
- Mineral spirits, for cleanup of oil-based finishes
- Good quality, natural-bristle brushes (for oil-based finishes)
- Good quality, synthetic-bristle brushes (when using the alternate water-based stain)
- 23-gauge headless pins

SHOPPING LIST

Recommended Wood: Oak

Alternate Wood: Poplar

Parts	Material	Quantity
A through I	1 x 8 oak	3 @ 10'
K through S	1 x 6 oak	2 @ 10'
	1 x 8 oak	1 @ 12'
J, T	1/4" oak plywood	1/2 sheet
Wood screws	#8 x 1-1/4"	32
Biscuits	#20	7

CUTTING LIST

Overall dimension: 18" x 33-1/2" x 37"			
Lower Bin			
Part	Name	Qty	Dimension
A	Ends	2	3/4" x 18" x 17"
B	Divider	1	3/4" x 17-11/16" x 15-1/2"
C	Bottom	1	3/4" x 15-1/4" x 30-1/2"
D	Top rails	2	3/4" x 3" x 30-1/2"
E	Lower rail	1	3/4" x 6" x 32"
F	Top	1	3/4" x 15-3/4" x 32-1/8"
G	Top bands	2	3/4" x 1-1/2" x 15-3/4"
H	Top band	1	3/4" x 1-1/2" x 33-1/2"
I	Bottom molding	2	3/4" x 1-1/2" x 17-3/8"
J	Back	1	1/4" x 16-5/8" x 31-1/4"
Upper Bin			
Part	Name	Qty	Dimension
K	Ends	2	3/4" x 15-1/2" x 17"
L	Bottom	1	3/4" x 15-1/2" x 30-1/2"
M	Rails	2	3/4" x 3" x 30-1/2"
N	Shelf	1	3/4" x 13-7/16" x 30-1/2"
O	Top	1	3/4" x 12" x 32-1/8"
P	Top bands	2	3/4" x 1-1/2" x 12"
Q	Top band	1	3/4" x 1-1/2" x 33-1/2"
R	Lower band	1	3/4" x 3/4" x 32"
S	Bottom molding	2	3/4" x 1-1/2" x 15-1/4"
T	Back	1	1/4" x 16-5/8" x 31-1/4"

WOOD FINISHING PRODUCTS

Recommended Finish

Prep: Minwax® oil based Pre-Stain Wood Conditioner
 Stain: Minwax® Wood Finish™ English Chestnut
 Finish: Minwax® Fast-Drying Polyurethane Semi-Gloss

Alternate Finish

Prep: Minwax® Water Based Pre-Stain Wood Conditioner
 Stain: Minwax® Water Based Wood Stain Toffee
 Finish: Minwax® Polycrylic® Protective Finish Semi-Gloss

BEFORE YOU BEGIN

Good craftsmanship begins and ends with good work habits, so make the following steps part of your routine workshop practice. If you have any doubts or questions about how to proceed with a project, always discuss them with your shop instructor.

- Carefully and fully review plans and instructions before putting a tool to the project lumber.
- Work sensibly and safely. Wear safety goggles when doing work that creates flying chips and sawdust; wear the appropriate respirator whenever making sawdust or working with thinners or other solvents.
- At the end of every work session, clean up your shop area and put away all portable tools.

CUTTING AND ASSEMBLY PROCEDURE

1. Glue up parts to make bin ends, A, J. The panels should be oversized so they can be cut to their finished size later.
2. Cut the lower bin ends, A, and divider, B, to 18" wide x 17" long. The divider will later be reduced in width to allow for the 1/4" back as the tapers are cut. With the size of these pieces, a table saw crosscut sled provides a good way of crosscutting.
3. Cut the two upper bin ends, J, to length. They don't need to be cut to the finished width yet.
4. Lay out the angles on the lower bin ends and divider. Measure and mark 5-1/2" up from the bottom on the front edge. Measure 15-1/2" from the back on the top and bottom ends. Connect the marks. Transfer the longer upper angle to the opposite face.
5. Cut the long upper angle by positioning the taper jig against the table saw fence and sliding the material into the jig. Adjust the taper jig for the correct angle by measuring from the layout line to the fence in two spots, preferably as far apart as possible. See Fig. 2. Adjust the angle of the taper guide until both measurements are the same. Be patient making this setup. Once it's correct, you'll have the angle for cuts on all five pieces (upper and lower ends and lower divider).
6. Position the rip fence by aligning the layout line with the right side of the table saw blade. Set the fence so you'll be cutting on the waste side of the line, leaving room to clean off the saw marks. Cut the two lower bin ends.
7. Carefully check the fence position. Move it toward the blade by 5/16" and cut the lower divider. This makes the divider narrower to allow for the bin back.
8. Mark the bottom edge of one upper bin end, J, at 15-1/2". Without changing the angle of the taper jig, relocate the fence to make a cut on the waste side of that measurement point. Cut the two upper ends.
9. Set the miter saw to an angle of 25 degrees. Cut the lower angles on all three lower bin parts. Save the off-cuts from this operation. You'll use them as clamping blocks later.

10. Joint or sand all angled cuts to remove saw marks. Note that if you're using the jointer, be sure you're cutting "downhill," (from the wide end of the board toward the narrow end).

11. Reduce the overall height of the lower bin divider by 1-1/2" (thickness of plywood top + plywood bottom) by making two cuts. In order for the angles to align, you must remove 3/4" from the top and 3/4" from the bottom.

12. Cut the lower bin bottom, C, to size. Carefully square the ends or the piece won't assemble correctly.

13. Rip an angle onto the front edge of the bottom to match the lower angle on the ends and divider, which should be 25 degrees.

14. Determine the upper angle of the lower bin using a sliding bevel square. See Fig. 3.

15. Prepare the rails for the upper and lower bins, D, E, M, and the bottom of the upper bin, L. Use the bevel square to set the angle of the table saw blade.

Woodworker's Tip: *The saw should be unplugged whenever setting the machine up. It's easiest to set the blade to the bevel square with the blade set high out of the table. Return the blade to the correct height before cutting.*

16. Cut the angle on the front edge of the front rail of both the upper and lower bins and on the front edge of the bottom of the upper bin.

17. Set up a dado head in the table saw or router bit in a router table to cut a 5/16" x 3/8" rabbet along the back edge of the bin ends and bottoms.

18. Rabbet the bin ends and bottoms to receive the back, J. Be careful to assure you're cutting the rabbet in the correct faces of all the parts. When rabbeting the bin ends, you must make a left and right. When rabbeting the bottoms, the correct face must be rabbeted to work with the angle on the front of the bottoms.

19. Mark out the screw locations on the bin ends. Screws should be 1-1/2" in from each end, with two more screws evenly spaced between those two. Screw holes are 3/8" from the end of the bin. Screw locations for the top rails should position the screws 3/4" in from each edge of the rail.

20. Drill and countersink for the screw holes. To allow for expansion of the solid wood ends relative to the plywood bottom, elongate the screw holes by shifting the drill back and forth. It's only necessary to do this on the bottom edges.

21. Lay out the screw locations on the lower bin bottom. The screws should be centered on the length of the bottom and have the same pattern as the bottom edge of the bin ends. Countersink and elongate the holes.

22. Lay out the screw holes in the top rails, D, for the lower bin. Cut the lower rail, E, for the lower bin to size. Measure the edge formed by the lower angle to determine the exact width of the rail. Dry-assemble the bin and measure outside to outside to determine the exact length of the rail.

- 23.** Rip a 25-degree angle on the bottom edge of the lower rail. Locate the divider for the lower bin by making it even with the end of the plywood base and measuring from the face of the divider to the opposite end of the bottom. Divide this number in two and cut spacers to this dimension.
- 24.** Dry-assemble the lower bin. Mark the position of the divider against the inside of the lower rail. See Fig. 4.
- 25.** Lay out and cut biscuit slots for #20 biscuits, centered on the lower rail. As an alternative to biscuits, you could screw the rail onto the ends and the divider and plug the screw holes.
- 26.** Cut the biscuit slot in the rail for the center divider by using scrap clamped as a fence for the biscuit joiner to rest against. The scrap should be clamped on the line established during the dry fit. See Fig. 5.
- 27.** Using a 1/4" round-over bit, round the front top corner of the lower rail. Sand the interior surfaces of all the project parts.
- 28.** Position the bottom in a vise. Make the end of the bottom even with a piece of scrap. Position the bin end on the end of the bottom. Pre-drill into the bottom and secure each end with four #8 x 1-1/2" wood screws. Do not use glue or the solid wood end will not be able to move seasonally. Attach both ends to the bottom.
- 29.** Clamp the top rails in place. Pre-drill and fasten the rails. The back edge of the rear rail should be flush with the rabbet. The front edge of the front rail should be flush the front of the end.
- 30.** Install the divider, using the spacers to locate it.
- 31.** Apply glue into the biscuit slots on the case. Insert biscuits. Apply glue over the biscuits and install the lower rail.
- 32.** Use the 25-degree off-cuts as clamp cauls to allow you to secure the lower rail. Put double-faced tape on the off-cut to secure it temporarily to the lower rail. Clamp. See Fig. 6.
- 33.** Lay out the position of the shelf, N, in the upper bin. It should be centered on the height of the bin.
- 34.** Cut shelf to size. Cut the correct angle on the front edge of the shelf.
- 35.** Use the biscuit joiner to cut slots for two #20 biscuits in each end of the shelf.
- 36.** Assemble the upper bin. Fasten one end to bottom, as before.
- 37.** Place unit on floor, protecting the end on the floor from getting scratched. Insert glue and biscuits in slots. Install the shelf.
- 38.** Connect the shelf with the other end using glue and biscuits and screws.
- 39.** Install the top rails, D. Clamp across shelf to close biscuit joints.
- 40.** Cut plywood for the top, E, to size. Machine solid bands, G, H, for the plywood top.
- 41.** Glue and clamp the bands to plywood. Allow the glue to dry; remove the clamps and sand the top.
- 42.** Using a 1/4" round-over bit, round the top and bottom corners of all three banding pieces on the tops.
- 43.** Make the bottom molding, I, for the lower bin. Round over the top and bottom corners and the front corner using a 1/4" round-over bit. Be sure to make left and right versions of these pieces.
- 44.** Drill and countersink from the inside out on the lower corners of the lower bin. The base molding is fastened with screws from the inside. Elongate the screw holes by rocking the drill to allow for seasonal movement.
- 45.** Screw the molding to the case, holding it flush with the case bottom. Do not use glue, or the case side won't be able to move seasonally.
- 46.** Pre-drill and drive screws through the top rails to fasten the lower bin top, H, to the case.
- 47.** Cut and install the lower bin case back, J.
- 48.** Cut the lower band for the upper bin.
- 49.** Glue and pin the band to the bottom of the upper bin.
- Woodworker's Tip:** *This is a great application for 23-gauge headless pins. They make a very tiny nail hole that is easy to fill but provides enough holding power.*
- 50.** Cut the upper bin bottom moldings, S. Cut an angle on the front end of the moldings to match that of the front of the upper bin. This piece of molding ends flush with the front edge of the case, not with the front of the bottom molding just installed.
- 51.** Round over the corners of the molding, as was done with the molding for the lower bin. As with the lower bin, pre-drill, elongate the holes, and fasten the moldings.
- 52.** Place the upper bin upside down on a bench. Pre-drill. Fasten the top. Fasten the back. Hand-sand the assembled piece to ease all sharp corners.

STAINING AND FINISHING

Woodworker's Tip: *Though you may be tempted to cut short your sanding, preparation and application time, don't do it. These tasks are very important steps in obtaining a high-quality finish. Remember, it is the finish, just as much as the fit and smoothness of the parts, that will have great bearing on how people judge your craftsmanship. To ensure an excellent result, follow the steps listed in this section as well as the instructions the finish manufacturer puts on its products.*

FINISHING TIPS

- Test the stains and finishes you are planning to use on scraps of wood. On the back of the scrap, mark the stain/finish combination and the type of wood. Allow all samples to dry thoroughly before making your final finish selection. Save your samples for quick reference on future projects.
- All stains and finishes must be allowed to dry thoroughly between coats. Remember that drying times can vary due to humidity and other climatic conditions.
- If you have some leftover stain or finish, wipe the can rim so that stain or finish in the rim won't dry out and prevent the lid from forming a tight seal.
- Brushes used for oil-based finishes must be cleaned with mineral spirits.

Recommended Finish

53. Before using Minwax® Wood Finish™ on a hardwood or softwood, apply Minwax® oil based Pre-Stain Wood Conditioner, following the directions on the can. Applying a pre-stain wood conditioner will help to ensure even absorption of stain and prevent blotchiness.

54. Apply the Minwax® Wood Finish™ you've chosen using a brush and a clean, lint-free cloth following the directions on the can. The brush will help you get the stain into the inside corners. Allow the Wood Finish™ to set for about 5 to 15 minutes, and then wipe off any excess. To achieve a deeper color, you may apply a second coat after 4 to 6 hours, repeating the application directions for the first coat. Allow the stain to dry for 24 hours before applying the protective clear finish.

Woodworker's Tip: *When wiping off stain, make certain that your last wipe with the cloth goes with the grain of the wood. This way, any stain you might miss during wipe-off will be visually minimized by the wood grain.*

55. Apply Minwax® Fast-Drying Polyurethane following the directions on the can. Use a good quality, natural-bristle brush. Allow the first coat to dry overnight.

56. The next day, sand all surfaces lightly with 220-grit or finer sandpaper using with-the-grain strokes. Dust off and wipe all surfaces with a cloth lightly dampened with mineral spirits. Apply a second coat of polyurethane and set the piece aside to cure overnight.

57. The following day, sand all surfaces lightly with 220-grit sandpaper. Dust off and wipe the piece with a cloth lightly dampened with mineral spirits and apply the third and final coat of polyurethane. Allow the finish to cure for a few days before using the piece.

Alternate Finish

58. Before using Minwax® Water Based Wood Stain, apply Minwax® Water Based Pre-Stain Wood Conditioner following the directions on the can. Applying it will help to ensure even absorption of stain, prevent blotchiness that can occur, and minimize grain raise. After 1 to 5 minutes, wipe off all excess conditioner using a clean, soft cloth. Wait 15 to 30 minutes, then use 220-grit or finer sandpaper to sand off any "whiskers" raised by the conditioner. Proceed to the staining within 2 hours.

59. Apply the Minwax® Water Based Wood Stain you've chosen to the wood, using either a synthetic brush or a clean cloth. Allow stain to penetrate no longer than 3 minutes. While stain is still wet, wipe off all excess with a clean cloth that's been lightly dampened with stain. Allow the piece to dry for 2 hours before applying a second coat, if desired. Allow the piece to dry overnight before applying the protective clear finish.

60. After allowing the piece to dry for at least 3 hours, apply Minwax® Polycrylic® Protective Finish following the directions on the can. Stir the can contents thoroughly before starting and periodically repeat the stirring during your work session.

61. Working a small area at a time to maintain a wet edge, apply the first coat. Work quickly and make the final strokes in each newly finished section using with-the-grain brushstrokes.

62. Allow the finish to dry a minimum of 2 hours. Then sand lightly with 220-grit or finer sandpaper wrapped around a soft backup block. Thoroughly dust off and wipe all surfaces with a cloth lightly dampened with water.

63. Repeat steps 61 and 62 to apply the second and final coat. Do not sand after the final coat. Allow the finish to cure for several days before using the piece.

PRODUCT SAFETY

For your safety and the safety of those you work with, always read the safety warnings, which manufacturers print on their labels, and follow them to the letter.

WARNING! Removal of old paint by sanding, scraping or other means may generate dust or fumes that contain lead. Exposure to lead dust or fumes may cause brain damage or other adverse health effects, especially in children or pregnant women. Controlling exposure to lead or other hazardous substances requires the use of proper protective equipment, such as properly fitted respirator (NIOSH approved) and proper containment and cleanup. For more information, call the National Lead Information Center at 1-800-424-LEAD (in U.S.) or contact your local health authority.

DANGER: Rags, steel wool, other waste soaked with oil-based stains and clear finishes, and sanding residue may spontaneously catch fire if improperly discarded. Immediately place rags, steel wool, other waste soaked with this product, and sanding residue in a sealed, water-filled metal container. Dispose of in accordance with local fire regulations.

When using oil-based wood finishing products:**CAUTIONS: CONTAINS ALIPHATIC HYDROCARBONS.**

Contents are **COMBUSTIBLE**. Keep away from heat and open flame.

VAPOR HARMFUL. Use only with adequate ventilation. To avoid overexposure, open windows and doors or use other means to ensure fresh air entry during application and drying. If you experience eye watering, headaches, or dizziness, increase fresh air, wear respiratory protection (NIOSH approved), or leave the area. Avoid contact with eyes and skin. Wash hands after using. Keep container closed when not in use. Do not transfer contents to other containers for storage.

FIRST AID: In case of eye contact, flush thoroughly with large amounts of water for 15 minutes and get medical attention. For skin contact, wash thoroughly with soap and water. In case of respiratory difficulty, provide fresh air and call physician. If swallowed, call Poison Control Center, hospital emergency room, or physician immediately.

DELAYED EFFECTS FROM LONG-TERM OVEREXPOSURE.

Contains solvents, which can cause permanent brain and nervous system damage. Intentional misuse by deliberately concentrating and inhaling contents may be harmful or fatal.

WARNING: This product contains a chemical known to the State of California to cause cancer and birth defects or other reproductive harm.

DO NOT TAKE INTERNALLY. KEEP OUT OF REACH OF CHILDREN. CONFORMS TO ASTM D-4326. Contact a physician for more health information.

When using water-based wood finishing products:

CAUTIONS: Use Only With Adequate Ventilation. To avoid overexposure, open windows and doors or use other means to ensure fresh air entry during application and drying. If you experience eye watering, headaches, or dizziness, increase fresh air, or wear respiratory protection (NIOSH approved), or leave the area. Avoid contact with eyes and skin. Wash hands after using. Keep container closed when not in use. Do not transfer contents to other containers for storage.

FIRST AID: In case of eye contact, flush thoroughly with large amounts of water. Get medical attention if irritation persists. If swallowed, get medical attention immediately.

WARNING: This product contains a chemical known to the State of California to cause cancer and birth defects or other reproductive harm.

DO NOT TAKE INTERNALLY. KEEP OUT OF REACH OF CHILDREN. CONFORMS TO ASTM D-4326. Contact a physician for more health information.

FIG 1.

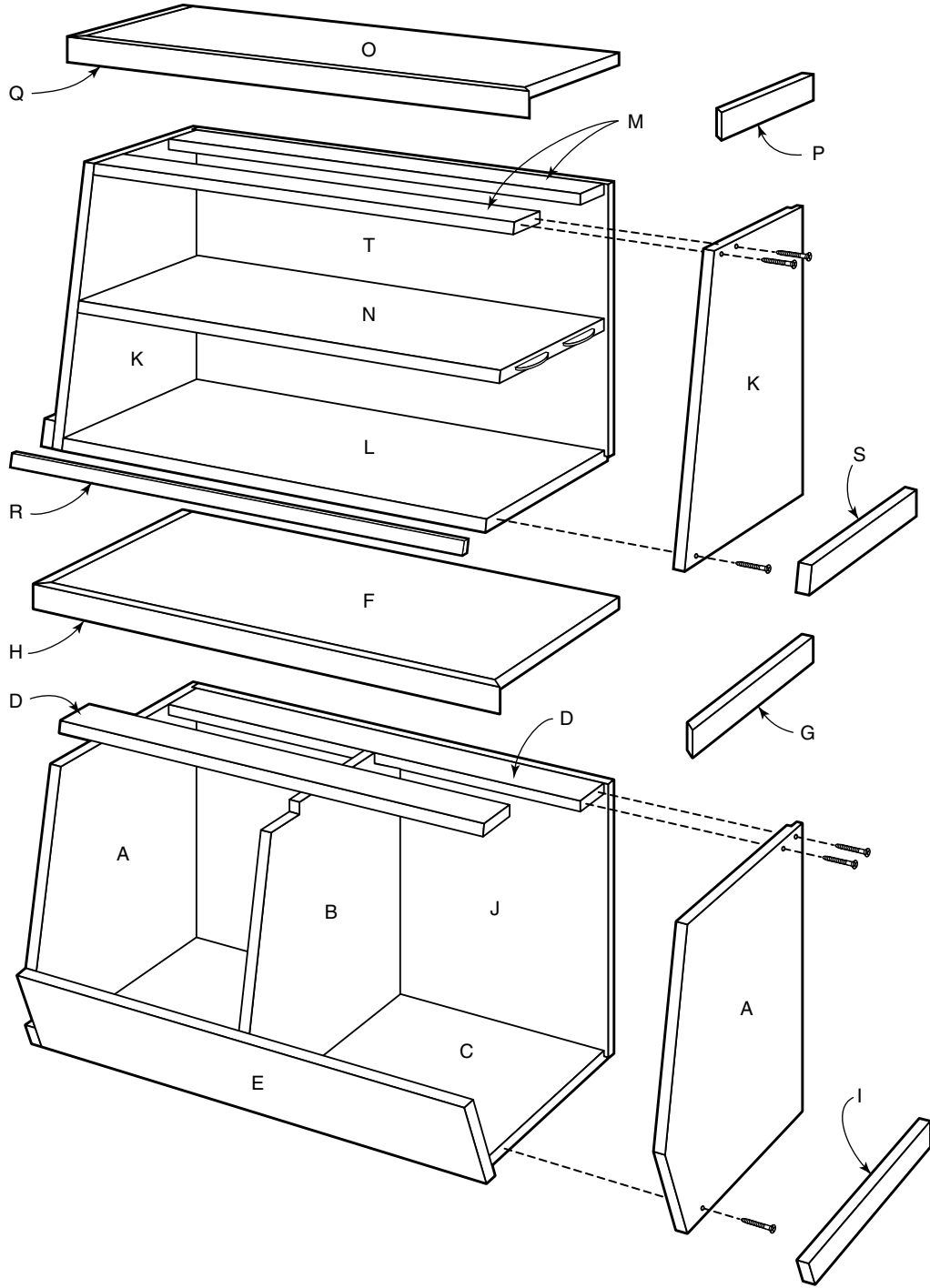

FIG 2.

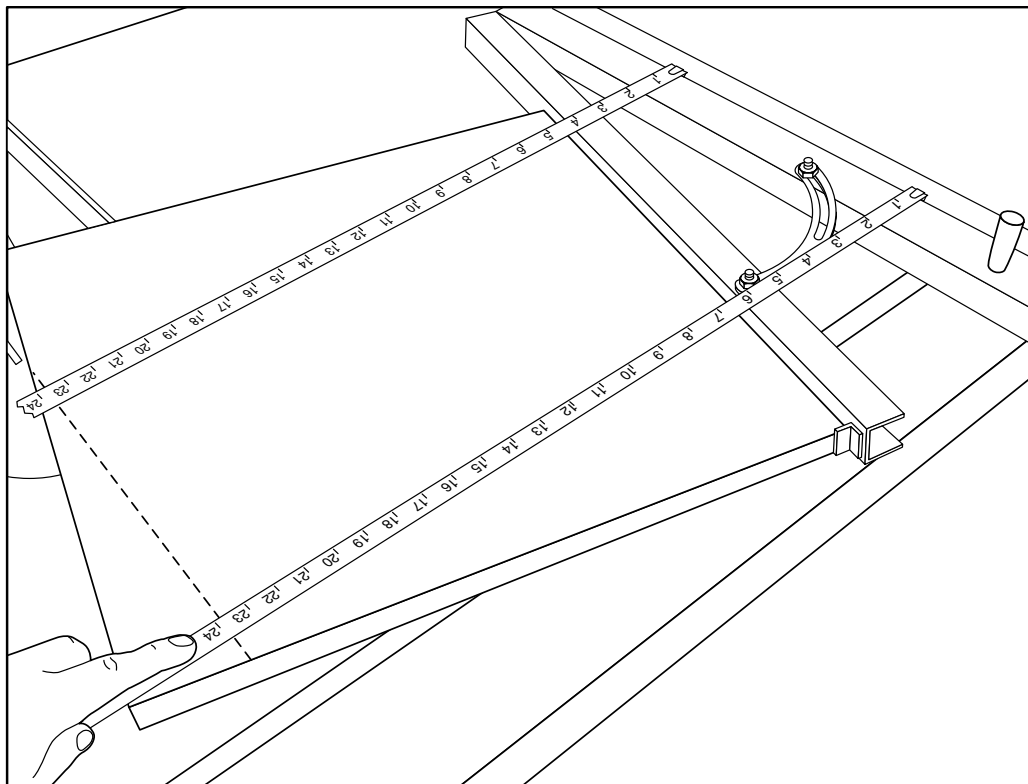

FIG 3.

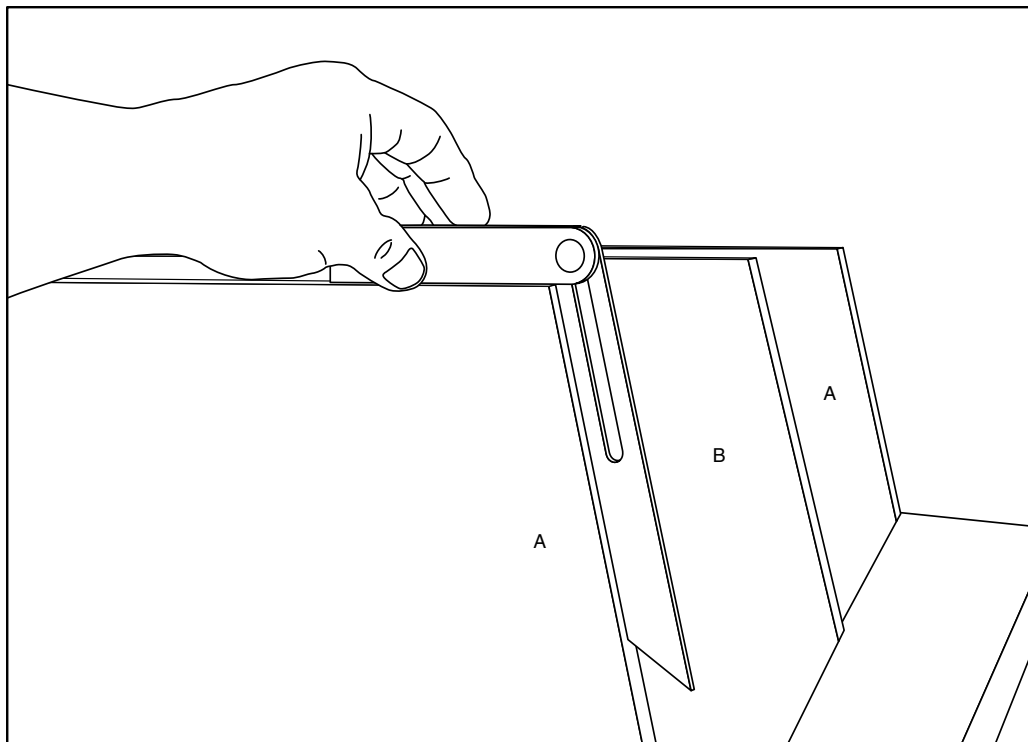

FIG 4.

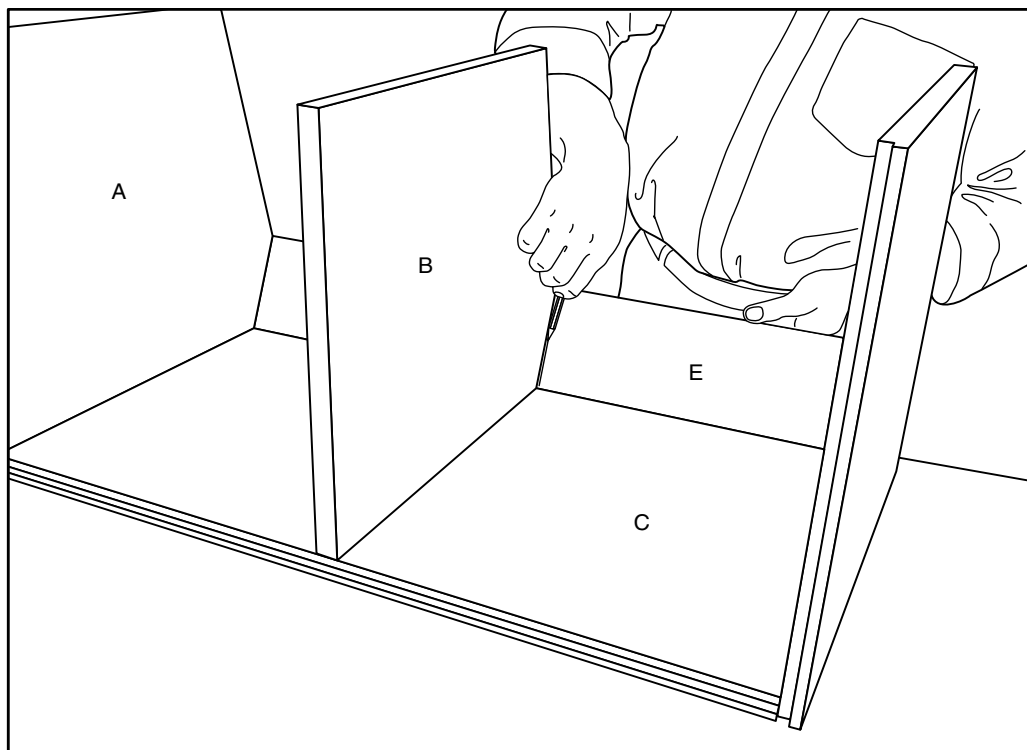

FIG 5.

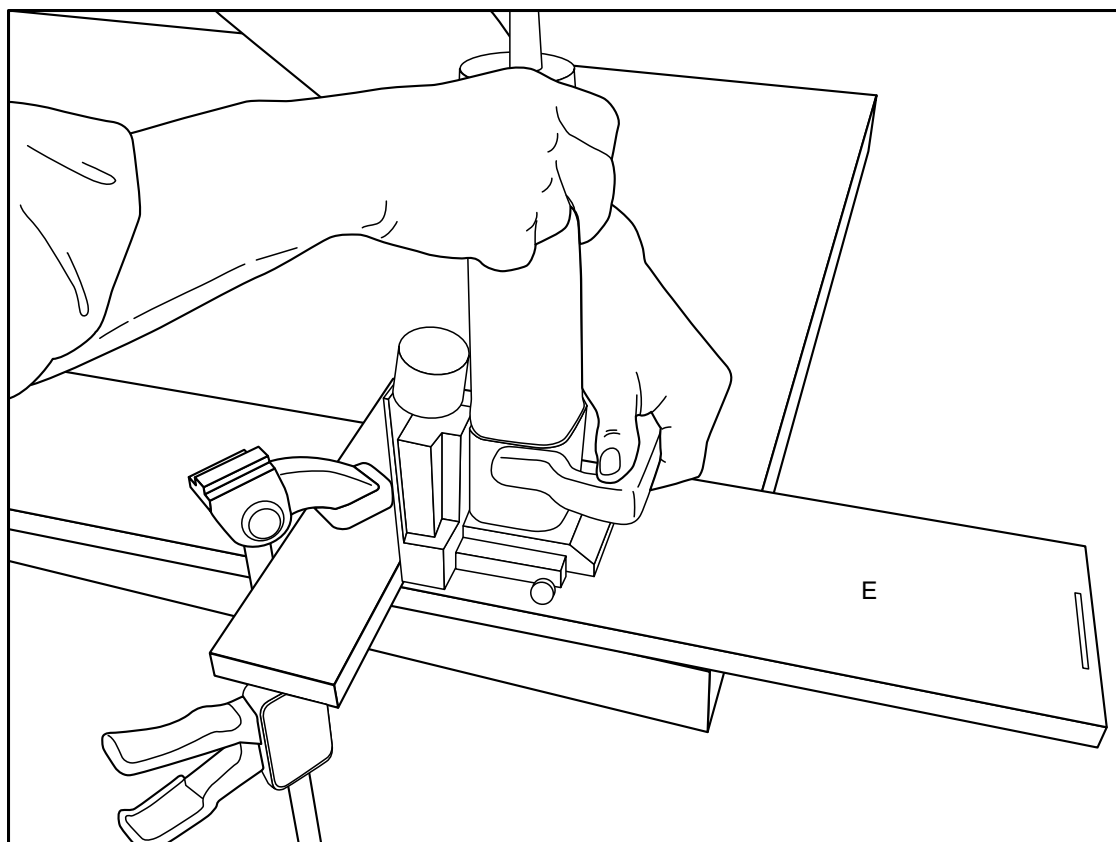

FIG 6.

